

**SE3102N Embedded 2D Barcode Scan  
Engine Intergration guide**



**SE3102N 系列二维码识读  
引擎集成手册**

苏州斯普锐智能系统有限公司

Email: [sales@isupermax.com](mailto:sales@isupermax.com)

Tel: 400-850-8151

# 目录

## 目录

Disclaimer 免责声明.....	3
Revision History 版本记录 .....	4
Chapter 1 Introduction 介绍.....	5
1.1 Product Overview 产品概述 .....	5
1.2 Illumination 照明指示 .....	5
Chapter 2 Installation 安装.....	6
2.1 General Requirements 一般要求.....	6
2.1.1 ESD 静电保护.....	6
2.1.2 Dust and Dirt 防尘防污.....	6
2.1.3 Ambient Environment 环境.....	6
2.1.4 Thermal Considerations 散热考虑.....	6
2.1.5 Installation Orientation 安装朝向.....	7
2.2 Optics 光学相关 .....	7
2.2.1 Window Placement 窗口放置.....	7
2.2.2 Window Material and Color 窗口材质与颜色.....	8
2.2.3 Scratch Resistance and Coating 窗口防刮与涂层 .....	8
2.2.4 Window Size 窗口尺寸 .....	8
2.2.5 Ambient Light 环境光.....	10
2.2.6 Eye Safety 人眼安全.....	10
2.2.7 Mounting 装嵌.....	10
Chapter 3 Electrical Specifications 电气特性.....	12
3.1 Power Supply 电源要求 .....	12
3.2 Ripple Noise 纹波噪声 .....	12
3.3 DC Characteristics 直流特性 .....	12
3.3.1 Operating Voltage 工作电压 .....	12
3.3.2 Current 电流.....	13
Chapter 4 Interfaces 接口.....	14
4.1 Host Interface Connector 主机接口连接器.....	15
4.2 Flat Flexible Cable 扁平柔性电缆.....	15
4.3 Communication Interfaces 通讯接口.....	16
4.4 Control Interfaces 控制接口 .....	16
4.4.1 Trigger 触发 .....	16
4.4.2 Beeper 蜂鸣器信号 .....	17
4.4.3 Decode LED 解码 LED 信号.....	18
4.4.4 SE3102N engine datasheet 引擎数据表 .....	19

# Disclaimer 免责声明

2014 Suzhou SuperMax Smart System Co., Ltd. All rights reserved.

苏州斯普锐智能系统有限公司对本声明拥有最终解释权。

Please read through the manual carefully before using the product and operate it according to the manual. It is advised that you should keep this manual for future reference.

请您在使用本产品前仔细阅读手册的所有内容，并根据手册操作设备。阅读后请将本手册妥善保存以备下次使用时查询。

Do not disassemble the device or remove the seal label from the device. Otherwise, Suzhou SuperMax Smart System Co., Ltd. does not assume responsibility for the warranty or replacement.

请勿自行拆卸终端或撕毁终端上的标签，否则苏州斯普锐智能系统有限公司不承担保修或更换终端的责任。

All pictures in this manual are for reference only and actual product may differ. Regarding to the product modification and update, Suzhou SuperMax Smart System Co., Ltd reserves the right to make changes to any software or product to improve reliability, function, or design at any time without notice. Besides, the information contained herein is subject to change without prior notice.

本手册中的图片仅供参考，请以实际产品为准。对于本产品的改良更新，苏州斯普锐智能系统有限公司保留修改软件或产品以改善可靠性、功能性或者结构性而不另行通知的权利。此外，本文档所包含的信息可能随时更改，不另行通知。

The products depicted in this manual may include software copyrighted by Suzhou SuperMax Smart System Co., Ltd or a third party. The user, corporation or individual, shall not duplicate, in whole or in part, distribute, modify, decompile, disassemble, decode, reverse engineer, rent, transfer or sublicense such software without prior written consent from the copyright holders.

本手册中描述的产品中可能包含苏州斯普锐智能系统有限公司或第三方享有版权的软件，未获得相关权利人的书面许可，任何用户、单位或者个人不能以任何形式对前述软件进行复制、散布、修改、反编译、反汇编、解码、反向工程、出租、转让及其它侵犯软件版权的行为。

This manual is copyrighted. No part of this publication may be reproduced or used in any form without written permission from SuperMax.

本手册包含的所有信息受版权的保护，苏州斯普锐智能系统有限公司保留所有权利。未经书面许可，任何单位及个人不得以任何方式或理由对本文档全部或部分内容进行任何形式的摘抄、复制。

Suzhou SuperMax Smart System Co., Ltd. reserves the right to make final interpretation of the statement above.

苏州斯普锐智能系统有限公司对本声明拥有最终解释权。

## Revision History 版本记录

Version 版本号	Description 版本描述	Date 日期
V1.0	Initial release. 初始版本	Nov 2nd, 2017

# Chapter 1 Introduction 介绍

## 1.1 Product Overview 产品概述

SE3102N series 2D barcode scan engines, a computerized image recognition system, bring about a new era of 2D barcode scan engines.

SE3102N紧凑二维码扫描引擎，运用先进的计算机识读系统，开创了影像式二维码识读引擎的新时代。

The SE3102N decoder ingeniously blends an advanced chip design & manufacturing, which significantly simplifies application design and delivers superior performance and solid reliability with low power consumption.

SE3102N的二维解码芯片，将先进的图像识别算法与先进的芯片设计与制造技术完美融合，极其简化了二维条码识读产品的设计难度，树立二维影像产品高性能、高可靠、低功耗的优秀标杆。

The SE3102N support all mainstream 1D and standard 2D barcode symbologies (e.g UPC/EAN, UPC/EAN with supplementals, Bookland EAN, ISSN, UCC Coupon Extended Code, Code128, GS1-128, ISBT 128, Code 39 )as well as (PDF417, MicroPDF417, Composite Codes, Data Matrix, Maxicode, QR Code, Micro QR, Aztec).

SE3102N可识读各类主流一维条码及标准二维条码，包括：UPC/EAN, UPC/EAN with supplementals, Bookland EAN, ISSN, UCC Coupon Extended Code, Code128, GS1-128, ISBT 128, Code 39等各种一维码。还支持识读PDF417, MicroPDF417, Composite Codes, Data Matrix, Maxicode, QR Code, Micro QR, Aztec等二维码。

## 1.2 Illumination 照明指示

The SE3102N has one white LED (5600K) for supplementary lighting, making it possible to scan barcodes even in complete darkness. The illumination can be programmed On or Off.

SE3102N本身有一颗白光LED（6500K 色温）提供的曝光辅助照明。可使得在完全黑暗的条件中，依靠自身的辅助照明而迅捷地识读条码目标。照明功能可以通过设置选择开启或关闭。

The SE3102N's LEDs imaging system is designed to work better with white light, so the engine shows better reading performance on barcodes printed in colour. The user can conduct some tests to determine the proper wavelengths to be used.

由于SE3102N照明是使用白光，而且透镜成像系统有选择性地对白光的支持更好，对于非白色的条码有较好的识读效果。对于使用了白色油墨的特殊应用，可尝试关闭本身的照明，而使用外界的其它照明进行辅助，以此获得良好的识读表现，建议用户进行对比实验后确定外界辅助光源的波长。

## Chapter 2 Installation 安装

### 2.1 General Requirements 一般要求

#### 2.1.1 ESD 静电保护

ESD protection has been taken into account when designing the SE3102N and the engine is shipped in ESD safe packaging. Always exercise care when handling the engine outside its package. Be sure grounding wrist straps and properly grounded work areas are used.

SE3102N已设计了对静电的防护，并使用了防静电包装，但在拆封和使用过程中仍需注意防静电措施，如使用接地腕带和工作区域接地等措施。

#### 2.1.2 Dust and Dirt 防尘防污

The SE3102N must be sufficiently enclosed to prevent dust particles from gathering on the imager and lens. Dust and other external contaminants will eventually degrade the engine's performance.

SE3102N在保存及使用过程中必须有足够的密封性，以避免粉尘、微粒或其它污染物聚集粘附在镜头、电路板、LED等部件上。粉尘微粒或污染物都会降低引擎的性能，甚至影响引擎的使用。

#### 2.1.3 Ambient Environment 环境

The following environmental requirements should be met to ensure good performance of the SE3102N:

SE3102N的正常使用需符合以下环境要求：

Working Temperature (工作温度)	0°C to 50°C
Storage Temperature (存贮温度)	-40°C to 70°C
Humidity (湿度)	0% ~95% (non-condensing)

#### 2.1.4 Thermal Considerations 散热考虑

Electronic components in the SE3102N generate heat during the course of their operation. Operating the SE3102N in continuous mode for an extended period may result in an increase in temperature by 20°C inside the engine. The following precautions should be taken when integrating the SE3102N:

电子元件会产生热量，特别是在持续工作的情况下，SE3102N的主要部件相对于环境温度可能达到20度的温升，可使用

以下方法保障其稳定工作：

- ✧ Reserve sufficient space for good air circulation during design.
- ✧ 设计时为SE3102N预留可形成自然对流或强制对流的空间。
  
- ✧ Avoid wrapping the SE3102N with thermal insulation materials such as rubber.
- ✧ 避免使用橡胶等隔热物质包裹设备。

### 2.1.5 Installation Orientation 安装朝向

The following figure illustrates a front view of the SE3102 after installation.

下图表示SE3102正确安装时的前视外观图。

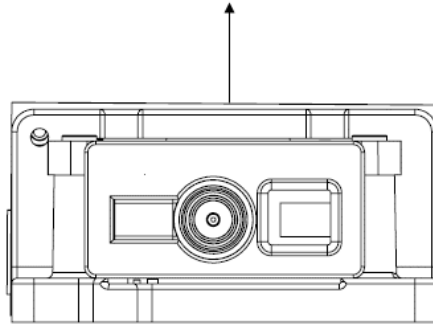

## 2.2 Optics 光学相关

### 2.2.1 Window Placement 窗口放置

The window should be positioned properly to let the illumination and aiming beams pass through as much as possible and no reflections back into the engine (reflections can degrade the reading performance).

窗口是安装在SE3102N引擎前方的透明介质，用于隔断产品内部与外部，并为引擎保留识读条码的光路。窗口的放置应尽可能使照明光束和瞄准光束射出，并防止反射光进入引擎中。若照明光束反射进入引擎，将会降低引擎的识读性能。

The window should be mounted close to the front of the engine (parallel). The maximum distance is measured from the front of the engine cover to the farthest surface of the window. Avoid unwanted reflections and use thin material for window so as to reach better reading performance. The distance from the front of the engine cover to the furthest surface of the window should not exceed 0.5mm and its better to make the window contact with the engine rubber cover.

窗口的安装应尽可能贴近于SE3102N引擎的前部，并平行于前端平面，其距离是通过测量引擎前端平面与窗口最远平面距离得到。为得到良好的识读性能表现，需避免引擎的照明光线通过窗口反射进入引擎，所以同时应尽可能减少窗口材料的厚度。窗口远端面与SE3102N前端面垂直距离不超过0.5mm，同时窗口的近端面最好与引擎前端面接触。

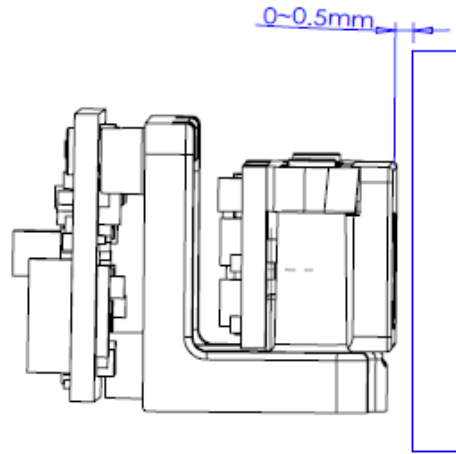

If the window is required to be in a tilted position, the above distance requirements should be met and tilt angle should ensure no reflections back into the lens.

若窗口需倾斜设计，距离的要求与平行安装相同，倾斜角度应保证照明光束被玻璃反射后不能进入镜头。

### 2.2.2 Window Material and Color 窗口材质与颜色

Wavelengths of illumination and aiming beams should be taken into consideration when choosing window material and color, to achieve the possible highest spectral transmission and lowest blurriness. It is suggested PMMA or optical glass with spectral transmittance over 90% and blurriness less than 1%. Whether to use an anti-reflection coating or not depends on the material and application needs.

窗口的材质和颜色的选择，应考虑照明光波长和瞄准指示光波长，使照明光束和瞄准光束的透过率尽可能高，同时保证模糊度尽可能低、折射率均匀。通常可使用 PMMA 或光学玻璃，窗口材质与颜色应使照明和瞄准光束的透过率大于90%，模糊度小于1%。窗口材质上可采用增透涂层，具体取决于材质和应用。

### 2.2.3 Scratch Resistance and Coating 窗口防刮与涂层

Scratch on the window can greatly reduce the performance of the SE3102N. It is suggested to use abrasion resistant window material or coating.

窗口上的刮痕脏污会大大降低SE3102N的识读性能，建议在设计上考虑窗口防刮防污，可考虑在窗口材质上选择高耐磨材料或使用耐磨涂层。

### 2.2.4 Window Size 窗口尺寸

The window must not block the field of view and should be sized to accommodate the aiming and illumination envelopes shown below.

窗口的尺寸的设计以保证不遮挡视场区域为基本要求，在此基础上尽可能不遮挡照明区域。窗口的尺寸设计可参考以下各光学区域示图：



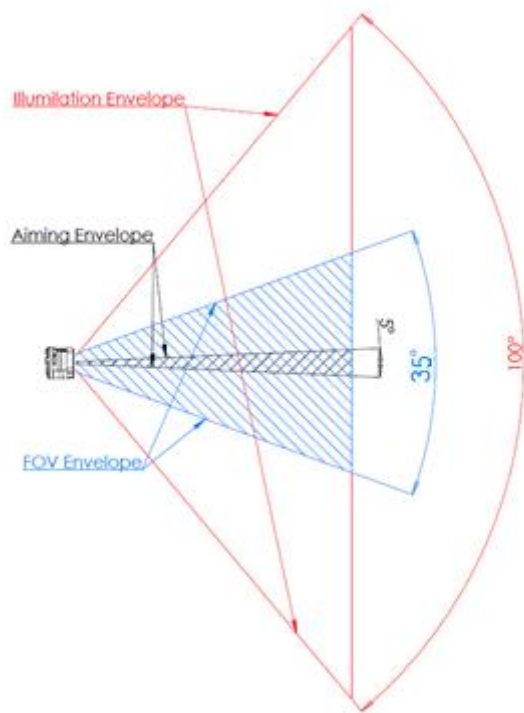
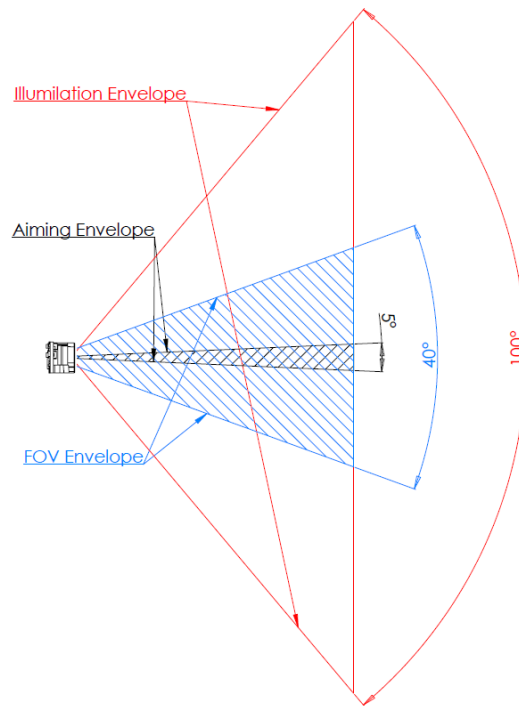

## 2.2.5 Ambient Light 环境光

The SE3102N may show better performance with ambient light. However, high-frequency pulsed light can result in performance degradation.

SE3102N在有环境光的情况下可获得更好的性能表现，但在高频脉冲闪光的环境下使用，性能表现可能会因为干扰而降低。

## 2.2.6 Eye Safety 人眼安全

The SE3102N has LEDs what create the aiming and illumination beams. These LEDs are bright, but testing has been done to demonstrate that the engine is safe for its intended application under normal usage conditions. However, the user should avoid looking into the beam.

SE3102N使用了发光二极管（LED）形成瞄准指示图形和照明，这些LED在正常的使用情况下产生的光波长范围是安全的。但发光强度仍然较高，在使用中应避免直视LED或将光束射向眼睛。

## 2.2.7 Mounting 装嵌

SE3102N Engine includes motherboard and Engine camera board assembly. The two components are Integrated in one piece.

SE3102N引擎包括主板和引擎影像板两部分，两部分被集成在一起。

The illustrations below show the mechanical mounting dimensions for the SE3102N. The structural design should leave some space between components and provide sufficient space for flat flexible cable.

进行集成应用时，可参考以下机械安装尺寸。结构设计上不要过于紧密，确保其它组件不会压迫电子器件，需要有足够的空间放置柔性线缆，同时也要给线缆留出恢复常态所需的空間。

Elements listed in previous sections should also be taken into consideration when integrating the SE3102N.

集成SE3102N时前文提及的部分也应考虑在内。

**Front View (unit: mm)**  
前视图(单位: mm)

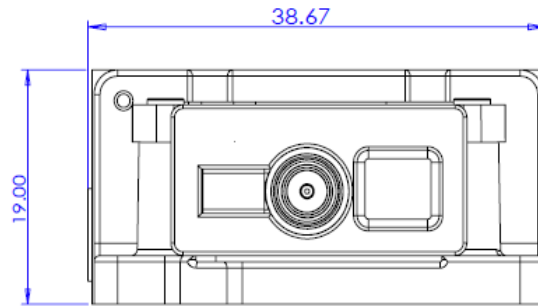

**Left View (unit: mm)**  
左视图(单位: mm)

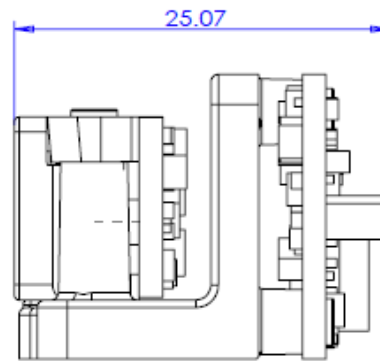

**Bottom View (unit: mm)**  
俯视图(单位: mm)

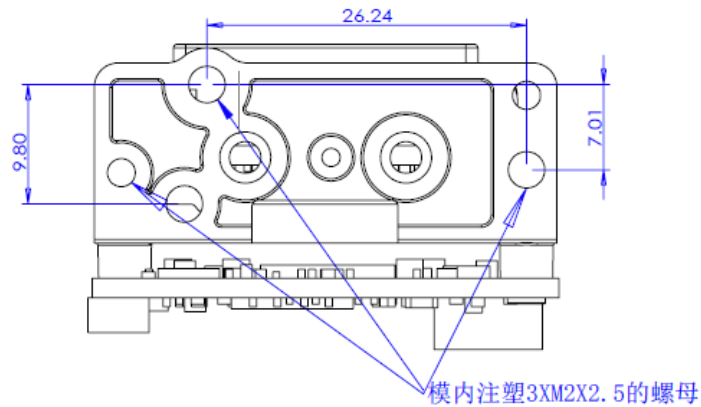

**Assembly View (unit: mm)**  
组装视图(单位: mm)

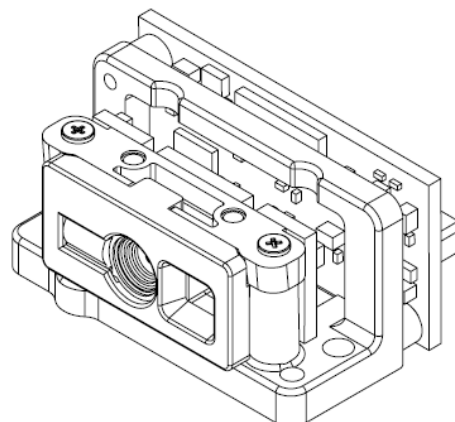

## Chapter 3 Electrical Specifications 电气特性

### 3.1 Power Supply 电源要求

Do not power up the SE3102N until it is properly connected. Be sure the power is cut off before connecting a flexible cable to or disconnecting a flexible cable from the host interface connector. This could damage the engine.

须在连接好SE3102N之后，才允许提供电源输入。如果在线缆带电时接插或拔离SE3102N（带电热插拨），将会损坏电子部件，请确保在进行线缆插拨时已切断电源。

Unstable power supply or sharp voltage drops may lead to unstable performance of the engine. Do not resupply the power immediately after cutting it off. The interval must be greater than 3 seconds.

不良的电源连接、或过短间隔的电源关闭开启操作、或过大的压降脉冲都可能导致SE3102N不能处于稳定正常的工作状态，需保持电源输入的稳定。在关闭电源后，需间隔3秒以上才可以再次开启电源。

### 3.2 Ripple Noise 纹波噪声

To ensure the image quality, a power supply with low ripple noise is needed. Acceptable ripple range (peak-to-peak) :  $\leq 50\text{mV}$  ( $\leq 30\text{mV}$  recommended).

由于SE3102N的电源输入直接提供给图像传感器使用，为保证图像质量，需使用低纹波噪声的电源输入。建议将纹波噪声控制在30mV以内（peak-to-peak，正负峰电压），至少保证不超过50mV（peak-to-peak，正负峰电压）。

### 3.3 DC Characteristics 直流特性

#### 3.3.1 Operating Voltage 工作电压

$T_a = 25^\circ\text{C}$ :

Parameter	Minimum	Typical	Maximum	Unit
$V_{CC}$	4.7	5	5.3	V
$V_{IH}$	$V_{CC}-0.5$	-	-	V
$V_{IL}$	-	-	0.5	V
$V_{OH}$	$V_{CC}-0.3$	-	-	V
$V_{OL}$	-	-	0.3	V

### 3.3.2 Current 电流

Ta=25°C, VCC=5V

Parameter	Average	Maximum	Unit
I <sub>OP</sub>	150	360	mA
I <sub>Standby</sub>	80	-	mA

## Chapter 4 Interfaces 接口

The following table lists the pin functions of the 12-pin host interface connector.

下表列出了12个pin连接器的名称和信号说明：

PIN#	Signal Name 信号名称	I/O 输入/输出	Function功能说明	
1	VCC	-	Power supply	输入电源
2	VCC	-	Power supply	输入电源
3	GND	-	Ground	接地
4	RX	I	TTL-232 receiving	TTL-232 接收
5	TX	O	TTL-232 transmission	TTL-232 发送
6	D-	I/O	USB D- differential data signal	USB 通讯 D-差分信号
7	D+	I/O	USB D+ differential data signal	USB 通讯 D+差分信号
8	GND	-	Ground	接地
9	BUZ	O	Beeper output. For the information of beeper driver circuit, see the “ <b>Control Interfaces</b> ” section. 蜂鸣器输出，详细信息见蜂鸣器驱动电路“接口控制”部	
10	LED1	O	Decode LED1 output. For the information of LED driver circuit, see the “ <b>Control Interfaces</b> ” section. 指示灯信号输出，详细信息见LED驱动电路“接口控制”部分	
11	LED2	O	Decode LED2 output. For the information of LED driver circuit, see the “ <b>Control Interfaces</b> ” section. 指示灯信号输出，详细信息见LED驱动电路“接口控制”部分	
12	TRIG	I	Trigger signal input: Driving this pin low for at least 10ms causes the SE3102N to start a scan and decode session. 触发信号输入，保持低电平10ms以上可触发读码。	

## 4.1 Host Interface Connector 主机接口连接器

The SE3102N's host interface connector is a 12-pin NONE ZIF socket which can be used to connect a host device (e.g., SE3102N software development board EVK) with a flat flexible cable. The following figures show the position and dimensions of the socket. (unit: mm)

下图是SE3102N的示意图。它采用ZIF12 PIN下接触插座，用柔性电缆与外设（主机）进行连接，（如SE3102N的接口板）。图中标示了插座的位置与尺寸（单位：mm）：

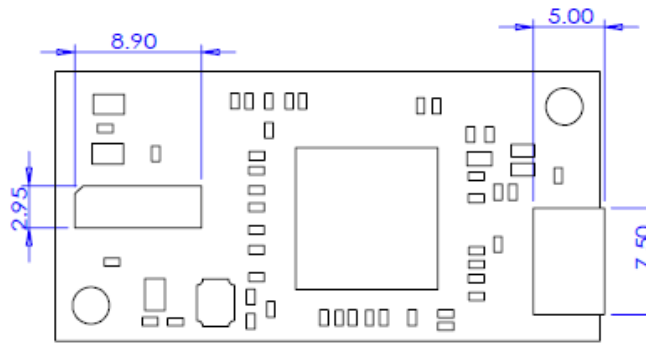

## 4.2 Flat Flexible Cable 扁平柔性电缆

A 12-pin flat flexible cable can be used to connect the SE3102N to OEM equipment or to the SE3102N EVK. The cable design must be consistent with the following specifications shown below. Use reinforcement material for the connectors on the cable and reduce cable impedance for reliable connection and stable performance.

12PIN柔性线缆可用于SE3102N与定制设备（OEM）或接口板的连接，规格需满足以下要求。为保证连接的可靠性工作稳定性，可在线缆的连接端使用加强材料，并减小导线上的阻抗。

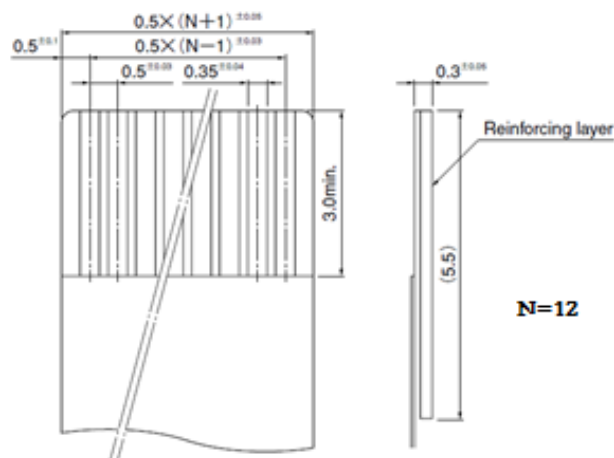

## 4.3 Communication Interfaces 通讯接口

The SE3102N can communicate with the host device through either TTL-232 serial port or USB port. It provides 3 communication modes:

SE3102N可以通过TTL-232串行通讯或USB接口与主机进行通讯，可使用以下三种通讯模式：

✧ TTL-232: This interface is applicable to most system architectures. For those requiring RS-232, a TTL-232 to RS-232 conversion circuit is needed.

✧ TTL电平信号（TTL-232）：此接口可适应大多数系统架构。对于某些系统需要使用RS-232形式的架构，需要有TTL-232到RS-232的转换电路。

✧ USB HID-KBW: Based on USB connection, the engine's transmission is simulated as USB keyboard input. It works on a Plug and Play basis and no driver is required.

✧ USB HID-KBW：基于USB的键盘模拟设备，可作为即插即用设备，不需要安装驱动程序。

✧ USB COM Port Emulation: The USB port on the host device is emulated as a serial port with the same data transmission and configuration as a real serial port. A driver is required.

✧ USB COM Port Emulation：基于USB的串行通讯模拟设备，可直接接驳PC使用，在主机上的USB端模拟出一个具有相同数据传输功能的串行端口，并且配置成真实的串行端口，需要安装驱动程序。

SX3100上不提供串行通讯接口的硬件流控。

## 4.4 Control Interfaces 控制接口

### 4.4.1 Trigger 触发

Driving the TRIG pin (PIN 12) on the host interface connector low for a specified time period causes the SE3102N to start a scan and decode session. The time period varies from one scan mode to another. Anti-shake mechanism is used in level trigger mode. Trigger is activated in this mode if the signal from the TRIG pin remains low for at least 10ms.

SE3102N的TRIG引脚（PIN12）在低电平输入时，将被识别为触发，对于触发的响应，不同的运行模式要求的维持时间不同。在电平触发模式中，使用了软件防抖机制，需要TRIG的电平保持10ms以上才被认为是有效触发开始。

For those scan modes with a timeout mechanism, the engine can automatically deactivate the trigger when a timeout occurs. After one trigger, the engine gets ready for next trigger only if the signal from the TRIG pin remains high for at least 10ms.

在一些运行模式下，内部有超时判断机制，即使一直保持 TRIG 的触发状态，一旦超过预设时间，都将停止识读，直到 TRIG 恢复非触发状态（输入高电平并保持 10ms 以上），才可接收新的一次触发。



## 4.4.2 Beeper 蜂鸣器信号

The SE3102N provides a pin (BUZ, PIN 9) on the host interface connector that provides a PWM output to an external driver circuit for generating audible feedback to the user to indicate statuses like power up, good decode or operation mistake. The PWM output is not strong enough to drive a beeper, so a beeper driver circuit is needed.

SE3102N中在BUZ引脚（PIN9）中使用PWM方式提供（Beeper）信号输出。在SE3102N启动、识读成功、操作错误等情况下根据设定会在BUZ引脚输出PWM信号，该信号输出通过外部的配套电路可驱动蜂鸣器发出提示声音。BUZ引脚的负载能力有限，不可直接驱动蜂鸣器发声，以免损坏SE3102N上的芯片。

The following beeper driver circuit is provided for reference.

可参考的蜂鸣器驱动电路如下图：

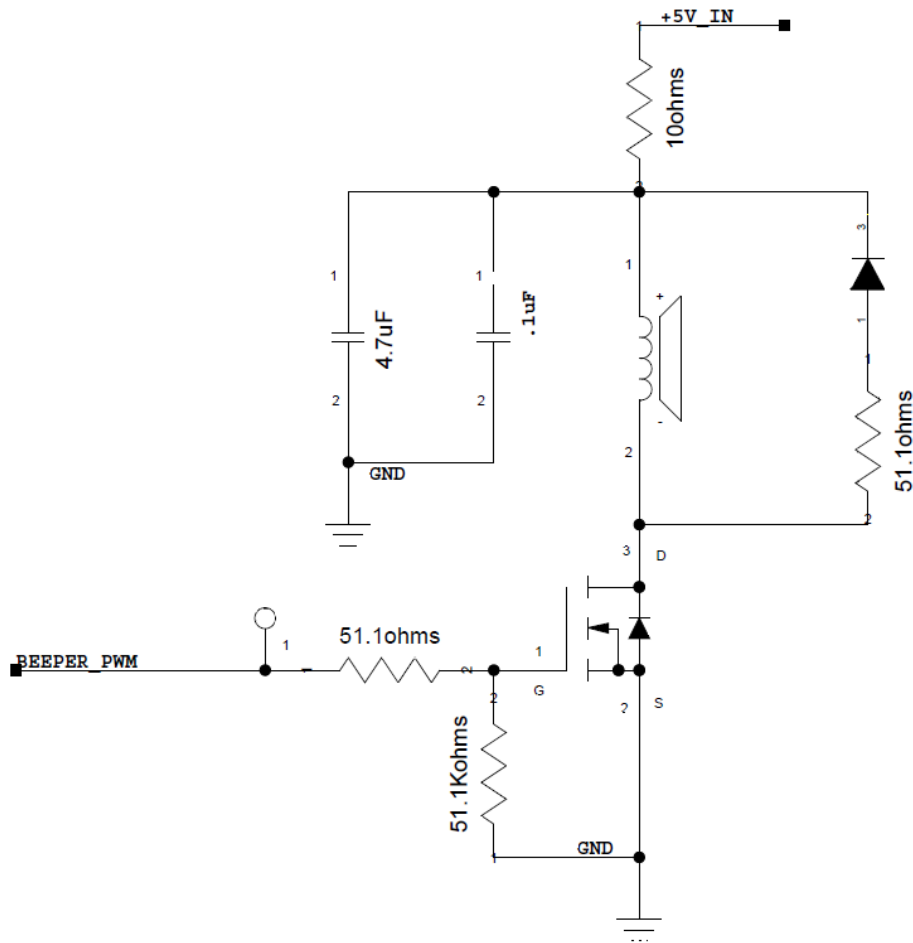

### 4.4.3 Decode LED 解码 LED 信号

The SE3102N provides a pin (LED, PIN 10, PIN 11) on the host interface connector that can be used by an external driver circuit to drive an LED to indicate a Good Decode status. When a good decode occurs, the signal from the LED pin turns from a low level into alternation of high and low levels and then back into a low level. This Decode LED output is not strong enough to drive an LED, so an LED driver circuit is needed.

SE3102N的LED（PIN10，PIN11）引脚，可提供在解码成功时发出电平提示信号，通常用于作为外部解码LED提示的输入控制信号。当解码成功发出提示时，LED引脚的电平将由低电平变为高电平与低电平交插出现，在维持一段时间后，最终恢复为低电平。LED信号输出引脚的负载能力有限，不可直接驱动发光二极管，需使用配套发光二极管驱动电路。

The following decode LED driver circuit is provided for reference.

可参考使用的配套 LED 提示驱动电路如下图：

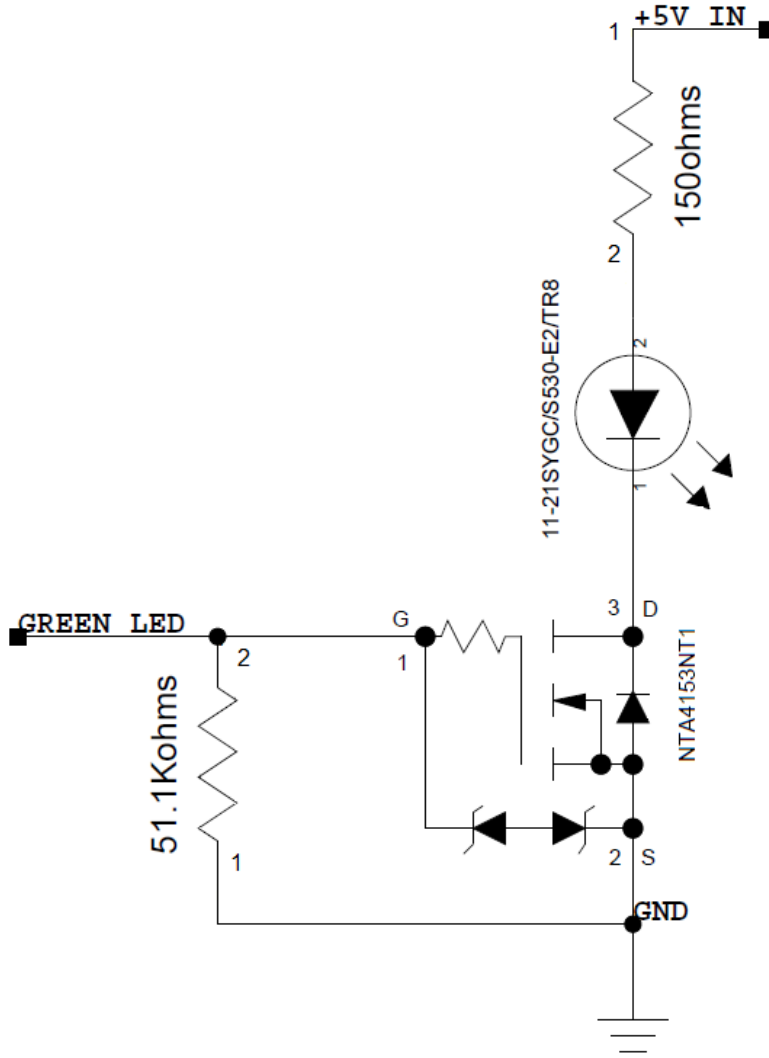

#### 4.4.4 SE3102N engine datasheet 引擎数据表

<b>Physical Characteristics—物理特性</b>	
Dimensions:	31.5mmX11mmX12mm (w/o Decode board) ; 38mmX19mmX8mm ( Decode board)
Weight:	9g
Voltage:	5VDC
Current:	400mA
<b>Performance Characteristics--执行特性</b>	
Light Source:	Aiming : 617nm ; illumination: 6500K LED
Field of View:	40° (H) x 35° (V)
Roll / Pitch / Yaw:	360°, ±65°, ±60°
Print Contrast:	25% minimum reflective difference
<b>Symbology Decode Capability--识读能力</b>	
1-D:	UPC/EAN, UPC/EAN with supplementals, Bookland EAN, ISSN, UCC Coupon Extended Code, Code128, GS1-128, ISBT 128, Code 39, Code 39 Full ASCII, Trioptic Code 39, Code 32, Code 93, Code11, Matrix 2 of 5, Interleaved 2 of 5, Discrete 2 of 5, Codabar, MSI, Chinese 2 of 5, GS1 DataBar variants, Korean 3 of 5, ISBT Concat
2-D:	PDF417, MicroPDF417, Composite Codes,Data Matrix, Maxicode, QR Code, MicroQR, Aztec
DOF	5mil Code39:50-110 mm ,13mil UPC:40-300 mm
Minimum Resolution	5 mil Code39
Interfaces Supported:	USB, 232
<b>User Environment--使用环境</b>	
Operating Temperature:	32° to 122° F / 0° to 50° C
Storage Temperature:	-40° to 158° F / -40° to 70° C
Humidity:	0% to 95%, non-condensing
Drop/Shock Specifications:	Withstands 10Gs 5' double amp
Ambient Light Immunity:	0 – 100,000 Lux.



苏州斯普锐智能系统有限公司  
地址：江苏省苏州市  
电话：+86 - (0) 512-62625385  
传真：+86 - (0) 512-62625386  
E-mail: [sales@isupermax.com](mailto:sales@isupermax.com)  
WEB: [www.isupermax.com](http://www.isupermax.com)